

# Brooks Stairlifts



## Brooks Stairlifts – Make life easier

We remain true to our guiding principles of quality and care. Here are just a few of the features that set us apart.

- 100% British made
- Easy to use controls
- Safety sensors
- Lockable swivel seat
- Slim fold-away design
- Fits to the stairs, not the wall
- Option to sit or stand
- 12-month warranty
- FREE no obligation quotation



## Generations past – The original stairlift

Mr Frederick Brooks made his first stairlift in 1973 for his wife Grace, a rheumatoid arthritis sufferer.

As a Daimler engineer, Mr Brooks put his many years' experience of craftsmanship and style into the original Brooks Lincoln Stairlift. Soon, people with mobility difficulties across the UK were contacting him to commission their own stairlift.

Thirty years later, Frederick Brooks' high standards remain. By combining today's advanced technology with a tradition of reliability and comfort, we guarantee that the Brooks Lincoln Stairlift will help you make the most of your home.

We are proud to be a 100% British manufacturer with tens of thousands of satisfied customers.



## Brooks provide – Professionalism & care

Safety and comfort come first at Brooks. The lift uses DC power packs that are automatically recharged when the lift is at rest. This means the lift is whisper quiet, incredibly smooth and will function even during a power cut.

Higher Elevation Ltd  
35 Union Street  
Maidstone  
Kent ME14 1ED

Tel: 0800 019 1306  
Email: [info@higherelevation.co.uk](mailto:info@higherelevation.co.uk)  
[www.higherelevation.co.uk](http://www.higherelevation.co.uk)

higher  
elevation  
SPECIALIST LIFT SERVICES



Lockable on/off switch allows the user to prevent others (e.g. children) from using the lift. Diagnostic digital display informs the user of the status of the lift.



Five safety sensors on the footrest and carriage stop the lift automatically if any obstruction is encountered on the stairs.



Easy-to-use joystick controls which are operated by the lightest touch.



Swivel seat means no need for twisting to get on or off.

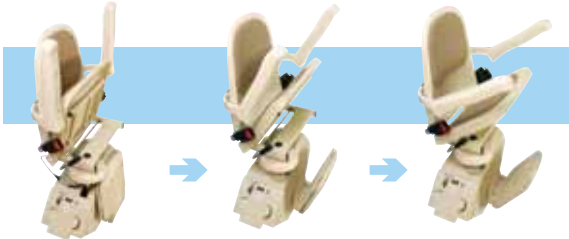

Folding seat and footrest allow full access to the stairlift.

Hinged Rail eliminates any problem you may have with obstruction to a doorway at the foot of the stairs.



Sit/Stand Stairlift gives the user the choice whether to sit or stand.



Perch Stairlift is ideal for customers who may have trouble sitting or bending at the knee.

## Specifications

<b>Motor power</b>	0.5hp	<b>Maximum capacity</b>	20 stones (127kg)
<b>Travel speed</b>	No greater than 0.15m/s	<b>Track</b>	Extruded Aluminium
<b>Method of drive</b>	Rack and Pinion	<b>Mains supply</b>	UK 240V, 50Hz Charger EC 220v, 50Hz Charger
<b>Motor output torque</b>	108 Nm		
<b>Power supply (battery)</b>	24v DC		

## Dimensions

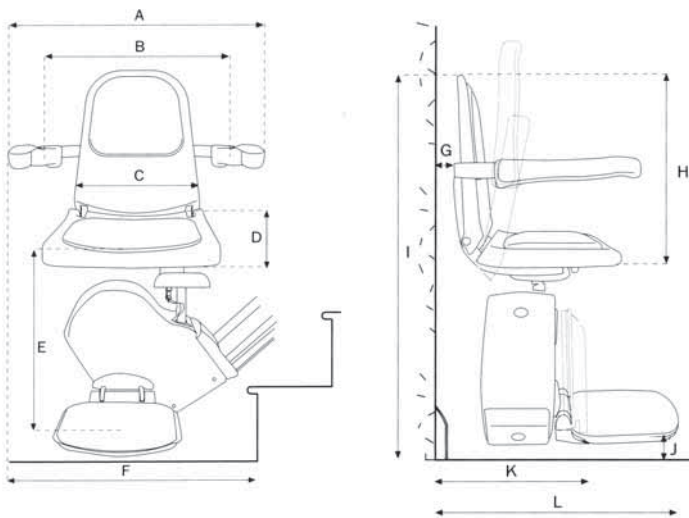

<b>A</b>	Width outside armrest	22"	560mm
<b>B</b>	Width inside armrest	17.5"	445mm
<b>C</b>	Width of backrest	14.5"	370mm
<b>D</b>	Depth of seat	16"	410mm
<b>E</b>	Top of footrest to top of seat	17.5"	445mm
<b>F</b>	Required space from bottom of stair	26"	660mm
<b>G</b>	Wall to seat width	1.5"	40mm
<b>H</b>	Overall height of seat	19.5"	495mm
<b>I</b>	Overall height	40"	1020mm
<b>J</b>	Footrest surface to floor	4.5"	115mm
<b>K</b>	Overall depth (folded)	13"	325mm
<b>L</b>	Overall depth (footrest down)	23"	585mm